

conical nest on c/l of 1.600 diameter within +/- .0005

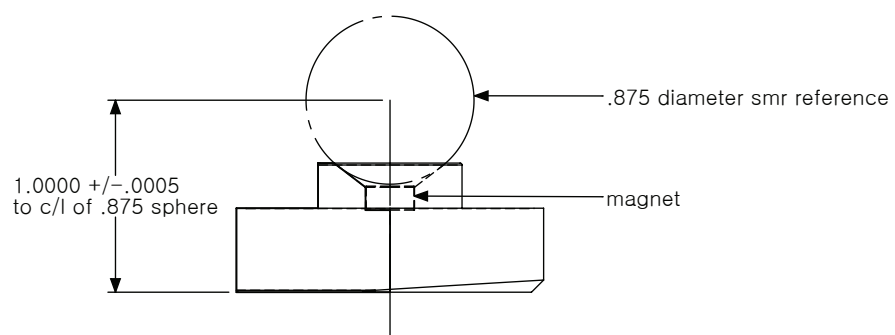

1.000 +/- .0005 to c/l of .875 sphere

.875 diameter smr reference

magnet

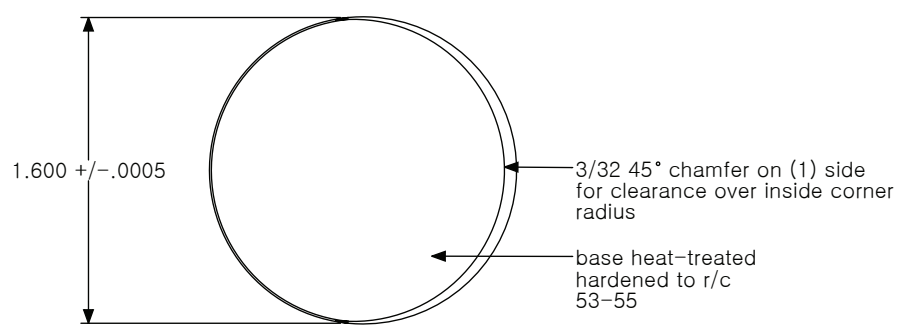

1.600 +/- .0005

3/32 45° chamfer on (1) side for clearance over inside corner radius

base heat-treated hardened to r/c 53-55