

precision (3) point nest on  
c/l of "A" diameter within  
 $\pm .0005$

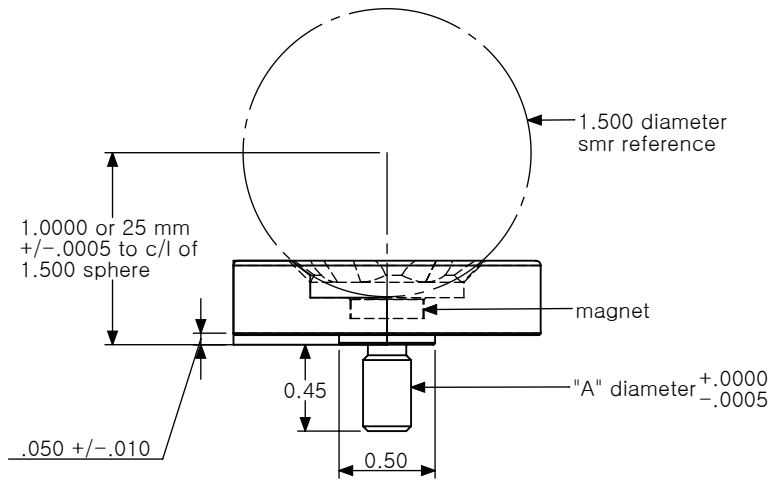

1.500 diameter  
smr reference

1.0000 or 25 mm  
 $\pm .0005$  to c/l of  
1.500 sphere

magnet

"A" diameter  $\begin{matrix} +.0000 \\ -.0005 \end{matrix}$

.050  $\pm .010$

0.45

0.50